



The Global Language of Business

GS1 Activate Brand Owner Guide

How to create GTINs and barcodes for your products using the Global Activate service component

Release 3.4, Approved, July 2021





Document Summary

Document Item	Current Value
Document Name	GS1 Activate Brand Owner Guide
Document Date	July 2021
Document Version	3.4
Document Issue	
Document Status	Approved
Document Description	How to create GTINs and barcodes for your products using the GS1 Activate Service Component

Disclaimer

GS1®, under its IP Policy, seeks to avoid uncertainty regarding intellectual property claims by requiring the participants in the Work Group that developed this **GS1 Activate Brand Owner Guide** to agree to grant to GS1 members a royalty-free licence or a RAND licence to Necessary Claims, as that term is defined in the GS1 IP Policy. Furthermore, attention is drawn to the possibility that an implementation of one or more features of this Specification may be the subject of a patent or other intellectual property right that does not involve a Necessary Claim. Any such patent or other intellectual property right is not subject to the licencing obligations of GS1. Moreover, the agreement to grant licences provided under the GS1 IP Policy does not include IP rights and any claims of third parties who were not participants in the Work Group.

Accordingly, GS1 recommends that any organisation developing an implementation designed to be in conformance with this Specification should determine whether there are any patents that may encompass a specific implementation that the organisation is developing in compliance with the Specification and whether a licence under a patent or other intellectual property right is needed. Such a determination of a need for licencing should be made in view of the details of the specific system designed by the organisation in consultation with their own patent counsel.

THIS DOCUMENT IS PROVIDED "AS IS" WITH NO WARRANTIES WHATSOEVER, INCLUDING ANY WARRANTY OF MERCHANTABILITY, NONINFRINGEMENT, FITNESS FOR PARTICULAR PURPOSE, OR ANY WARRANTY OTHERWISE ARISING OUT OF THIS SPECIFICATION. GS1 disclaims all liability for any damages arising from use or misuse of this document, whether special, indirect, consequential, or compensatory damages, and including liability for infringement of any intellectual property rights, relating to use of information in or reliance upon this document.

GS1 retains the right to make changes to this document at any time, without notice. GS1 makes no warranty for the use of this document and assumes no responsibility for any errors which may appear in the document, nor does it make a commitment to update the information contained herein.

GS1 and the GS1 logo are registered trademarks of GS1 AISBL.

Table of Contents

1	What is GS1 Activate?	5
1.1	GS1 Activate information and resources	5
1.2	Terminology	5
1.3	Log in to GS1 Activate	5
1.4	Agree to terms and conditions	5
1.5	Minimum system requirements	5
2	GS1 Activate home page	6
3	Get started!	8
3.1	Initial steps	8
3.1.1	View the support videos and read the user guide	8
3.1.2	Define initial settings.....	9
4	View, search and sort product lists	12
5	Add a new product	13
5.1	Step 1 — Get started	13
5.2	Add a base unit product	15
5.2.1	Step 2 — Describe your product	15
5.2.2	Step 3 — Get a GTIN	20
5.3	Add a higher-level unit product.....	20
5.3.1	Step 2 — Describe your product	21
5.3.2	Step 3 — Get a GTIN.....	23
5.4	Request a GTIN (for Payment On Demand users only)	24
5.4.1	Step 3 — Request received	24
5.4.2	Step 4 — Get a GTIN.....	25
6	Edit, delete or finalise a base unit product	26
6.1	Find draft products to edit, delete and finalise	26
6.2	Editing product attributes during the 3-hour editing period.....	27
6.3	Editing product attributes after the 3-hour editing period elapses.....	27
7	Import a batch of products with a data file	28
7.1	Fill in the template	29
7.1.1	Product Datasheet – attributes	30
7.1.2	Higher-level sheet-attributes	32
7.1.3	Instructions tab	32
7.2	Upload products using the template upload wizard	32
8	Create barcode images	35
9	Export products	37
10	Share product data with GS1	39
11	Appendices	41
A.1	Appendix 1 – Examples of product classification: selecting the right properties	41



A.2	Appendix 2 – Using the indicator digit method	43
A.3	Appendix 3 – Supported Barcodes	44

1 What is GS1 Activate?

GS1 Activate is a web-based service to help you get GS1 barcode numbers and barcodes (also called Global Trade Item numbers or GTINs) for your products so you can sell them in retail.

1.1 GS1 Activate information and resources

GS1 Activate version

This guide aims to describe the functionality of GS1 Activate version 3.2. Incremental updates to the application may result in a mismatch between web pages or other content in this guide and the application. Ensure that you have the latest version of this guide.

Latest version of this document

Contact GS1 for the latest version of this document and additional information.

GS1 Activate website

- www.gs1.org/services/activate

Support

- See section 3.1 – [Training, additional resources and support](#)

1.2 Terminology

In this guide:

- The terms "GS1 Activate" and "Activate" refer to the "Global Activate service component".

1.3 Log in to GS1 Activate

1. Go to <https://activate.gs1.org>.
2. Type in your username and password from the welcome email you received from GS1.

1.4 Agree to terms and conditions

On your first login, you must agree to the terms and conditions.

1. Select **I agree to the Terms and Conditions**.
2. Click **Submit**.

1.5 Minimum system requirements

GS1 Activate is a web application that does not install any plugin or agent on the client-side. It works on all modern browsers (Chrome, Firefox and Safari) and consumes CPU, memory and network resources from the client-side.

To enhance browser performance, consider the following factors:

- A minimum of 2GB of memory and a regular processor is essential to run this application on tablets and computers.
- When you access the application from a single window, GS1 Activate utilizes 500 MB of memory, approximately. Memory utilization increases for each additional window.
- By default, modern browsers enable Graphics Processing Unit (GPU) acceleration to render CSS, images for the application. GPU acceleration consumes a minimum of 300 MB.

2 GS1 Activate home page

When you log in, the GS1 Activate home page appears.

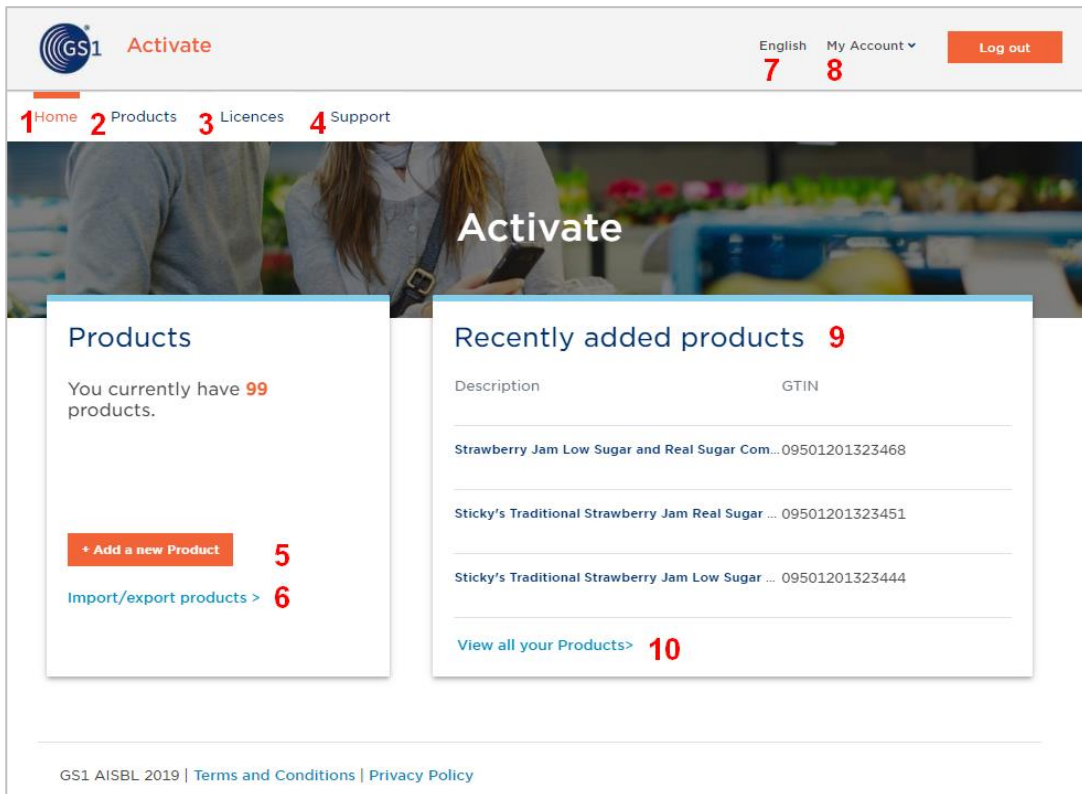

Figure 2-1: GS1 Activate home page

The following options on the GS1 Activate home page ([Figure 2-1](#)) help you perform specific actions:

1. **Home** — Return to the home page.
2. **Products** — Open the **Products** page, to:
 - Add a new product (see #5).
 - Import / export products (see #6).
 - View a list of all products.
 - Filter the products listed by searching for a word in the product description or GTIN.
 - Sort the list by Description, GTIN, or Status (Active or Draft).
 - Select products to export to a spreadsheet.
3. **Licences** — View your licence(s) and set some licence options or parameters.
 - View status (active/inactive), licence number and remaining GTIN capacity.
 - For each licence: select a nickname, assign GTINs automatically (one licence must be set to yes as the automatic default for assigning licences) and start GTINs from a value you choose.
4. **Support** — Get help.
 - Contact support to open a ticket.
 - Go to the GS1 Activate Training and Resources page in the MO Zone portal.
 - Download the GS1 Activate user guide.

5. **Add a new Product** — Launch a short wizard with prompts that guide you to create a product and generate a GTIN. Alternatively, Payment On Demand users can request a GTIN.
6. **Import / export products** — Launch a short wizard with prompts that guide you to upload a batch of products, including or not including GTIN numbers to assign, using a template file (Excel spreadsheet).
7. **Select language (English)** — If your MO has installed multiple language options, you can choose the language to use for both the user interface and product descriptions.
8. **My Account** — Manage your profile:
 - Change your password.
 - Manage suggestions – Answer questions to provide information to “pre-set” the system so that you can more quickly and easily upload products. Information that is requested:
 - What are the most common brand names of the products you sell?
 - What are the most common sub-brand names of the products you sell?
 - Which countries do you sell most often to?
9. **Recently added products** — View the most recent products added. Click a product to see detailed product information.
10. **View all your products** — View the **Products** page, to:
 - Add a new product (see #5).
 - Import / export products (see #6).
 - View a list of all products.
 - Filter the products listed by searching for a word in the product description or GTIN.
 - Sort the list by Description, GTIN, or Status (**Active** or **Draft**).
 - Select products to export to a spreadsheet.

3 Get started!

GS1 Activate lets you upload or create one product at a time. A feature in GS1 Activate helps to speed this process along if you have many products with similar brand names, sub-brand names, or markets (countries).

Another feature allows you to upload a product but keep it in draft status indefinitely, to allow you to pre-load products before they come to market, or for any other reason. In draft status, products are not yet "finalised" or rendered "active".

A product is rendered active:

- If its status changes from draft to finalise.
- If a product data file is uploaded and the product is finalised.

3.1 Initial steps

The first steps to start using GS1 Activate are:

- [View the support videos and user guide](#)
- [Define initial settings](#)

3.1.1 View the support videos and read the user guide

On the GS1 Activate home page, click the **Support** tab to view the GS1 Activate user guides and contact the GS1 customer support team. View the Getting Started video, read the FAQs and the rest of this guide.

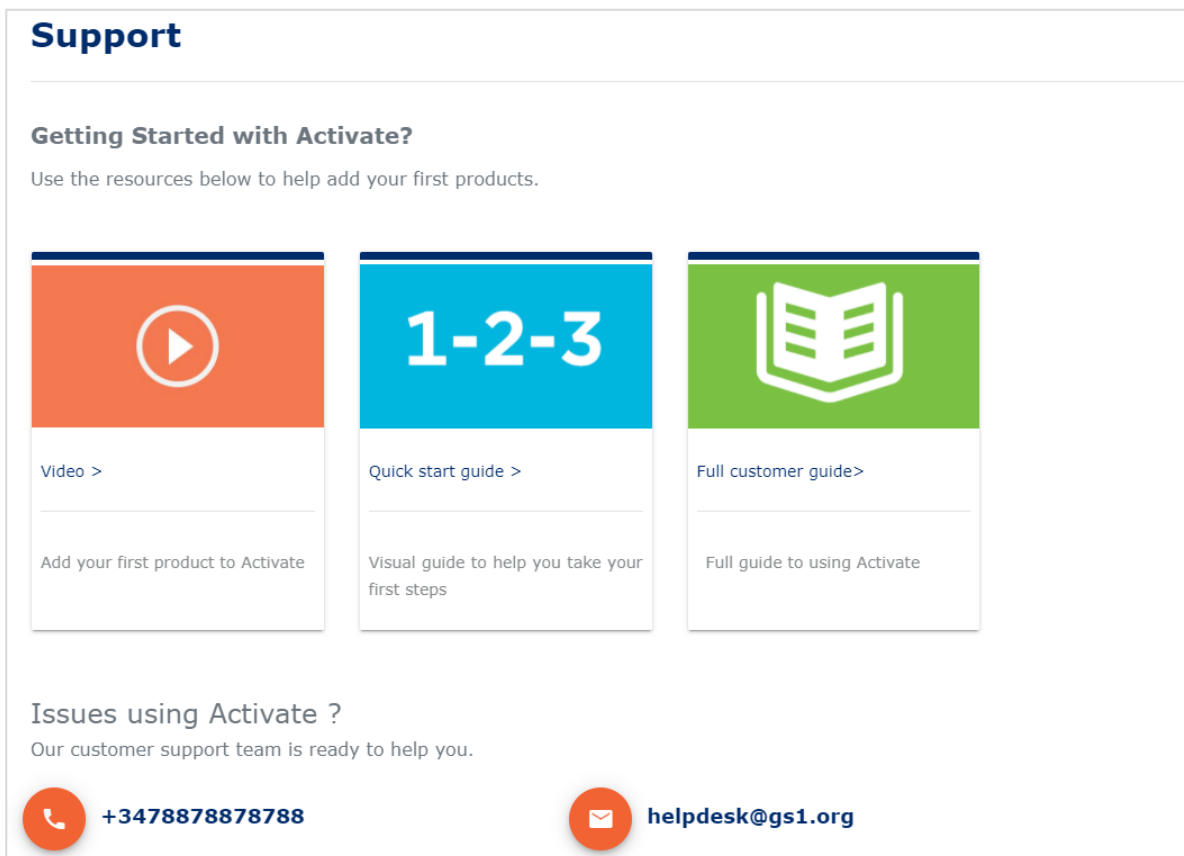

Figure 3-1: Support page

- Video on adding your first product: https://www.youtube.com/watch?v=BvPtmh_tirY

- GS1 Activate quick start guide: www.gs1.org/docs/activate/Activate_Quickstart_Guide.pdf
- Download this guide – ensure that you have the latest version! www.gs1.org/sites/default/files/docs/activate/Activate_User_Guide.pdf
- Contact the GS1 customer support team.

3.1.2 Define initial settings

When you first start to use GS1 Activate, it's helpful to set up some user options and preferences before you create any products. This section provides guidance to set up the following initial user options and preferences:

- [Select the default language](#) for the application and products (if provided by your MO).
- [Pre-load "suggestions"](#) – the brand names, sub-brand names and countries you most commonly use or market your products to.
- [Set user preferences](#) for your licence(s) and assign GTINs.

3.1.2.1 Select language

If your MO has installed multiple language options, you can choose the language to use for both the user interface (application) and product descriptions.

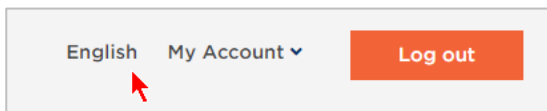

Figure 3-2: Choose language

3.1.2.2 Pre-load suggestions

From the GS1 Activate home page, under **My Account**, click **Manage suggestions** to launch a short wizard with prompts, which guides you to provide information to pre-load options into GS1 Activate so that you can upload products more easily. This is an important step for all brand owners to complete before starting to upload individual products via the web interface. It is especially important if you have many products to upload. When you pre-load options into GS1 Activate, you will not need to enter repetitive information for each product. The information is provided back to you in options pages so that you can specify product information more easily.

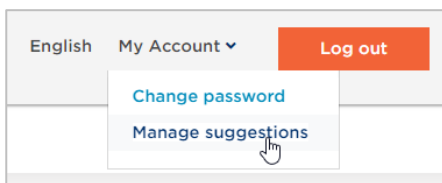



Figure 3-3: Manage suggestions

- ✓ **Note:** The **Managing suggestions** settings do not affect the uploading of products using template files.

The best option is to prepare a simple comma-separated list of these to copy and paste. Or, simply type each one, with a "comma" to enter it in the system.

The following information is requested:

- What are the most common brand names of the products you sell?
- What are the most common sub-brand names of the products you sell?
- Which countries do you sell most often to?
- What category do most of your products come from?

- 
Note: You can edit these lists or delete items no longer needed at any time. It is not mandatory to complete these before entering products.

For example:

Welcome to Activate
Before you get started, please provide the following information.

What are the most common brand names of the products you sell?

CalorFree x
BestFlavor x
ExtraFresh x

Figure 3-4: Managing suggestions question

3.1.2.3 Manage licences

Open the **Licences** tab to view and manage your licences (prefixes).

You can view information for the following:

- **Status** — is this licence active or inactive?
- **Licence** — the identification number of each licence
- **Remaining capacity** — for each licence, how many GTINs do you have available?

You can view and configure options for the following:

- **Nickname** — A label you choose to help remember details about the licence, such as to use it specifically for a product line or a specific market.
- **Use this licence (recommended)** — If you have more than one licence, you **MUST** choose which licence to use "automatically" (by default) when you upload products via the web application or template file.
- **Start GTINs from a specific number (not recommended)** — If desired, set the GTIN number to use as the starting point to sequentially assign GTINs to products, when you upload products via GS1 Activate or template file.

Status	Licence	Nickname	Remaining capacity	Use this licence (recommended)	Start GTINs from a specific number (not recommended)
Active	950234567214	Add nickname	1	<input type="checkbox"/>	
Active	950345234123	Add nickname	0	<input type="checkbox"/>	
Active	95034567	Indonesia 	9999	<input checked="" type="checkbox"/>	Add value

Figure 3-5: Available licences

3.1.2.3.1 Choose a licence (mandatory task)

- If you have only one licence, GTINs are automatically assigned to this licence.
- If you have more than one licence, you must choose which licence to use "automatically" (by default) when you upload products. Select the licence you want to use in the **Use this licence (recommended)** column.
- If you do not choose which licence to use or whenever more licences are available, the following dialog box appears:

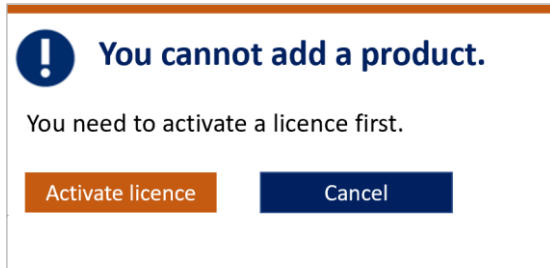

Figure 3-6: Licence activation

- When you add products using GS1 Activate or upload products using a template, the products you add are assigned a GTIN from the licence that you select in the **Use this licence (recommended)** column.
- Contact your member organisation when no licences are available. In this scenario, the following dialog box appears:



Figure 3-7: Contact member organisation

3.1.2.3.2 Optional tasks

- Create or change a **Nickname**. Use this setting to name a licence to help you manage licences and the assignment of GTINs. For example, you can label one licence for domestic products, and another licence for export items.
- If desired, use the **Start GTINs from a specific number (not recommended)** column by setting the GTIN number to use as the starting point to sequentially assign GTINs to products, when you upload products with the web application or template file. If you create products one at a time without this option, GS1 Activate assigns GTINs randomly. This option is useful if you want your products to have sequential GTINs.

4 View, search and sort product lists

Open the **Products** tab to view, search and sort your products in a table format. All products are listed in a series of pages.

To sort the list

- Click **Description**, **GTIN**, or **Status** to sort ascending or descending by this field. Status is sorted by *active* or *inactive*.

To search or filter the list

- Use the search field to filter results. Enter key terms or type first three characters in the product description to search for the required product.
- You can search by:
 - As few as three characters for any word in the description.
 - The GTIN or part of the GTIN.
 - Only one string in the search.

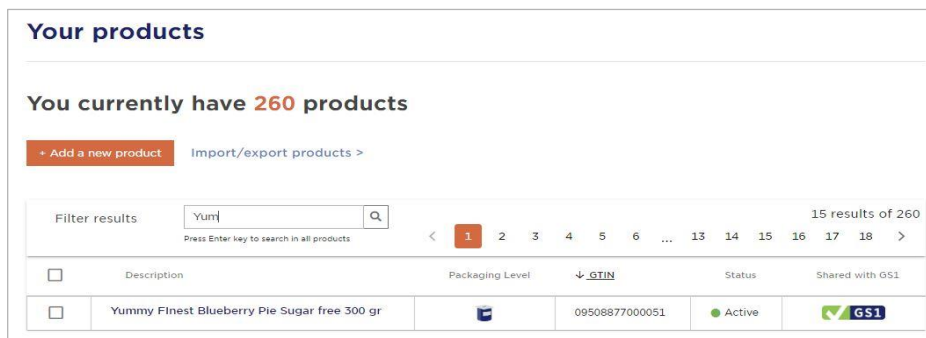

Figure 4-1: Your products page

5 Add a new product

On the home page or from the **Products** tab, click **+ Add a new product**. This launches a three-step wizard with prompts that guide you through the steps to create and upload a product, assign a GTIN, create a barcode image, etc.



Figure 5-1: Initiates the product wizard

5.1 Step 1 — Get started

The first step of the wizard is the **Get started** page that presents you with three “either/or” questions. In this step, you provide top-level information about your product, to classify what it is.



Figure 5-2: Step 1 of the product wizard

1. At Step 1 ([Figure 5-3](#)) **choose one answer for each question.**
 - Is the product sold to consumers?
 - **Yes** — The product is sold to consumers at point-of-sale.
 - **No** — The product is not sold to consumers at point-of-sale.
 - Is the product fixed or variable?
 - **Fixed product** — Unit price of the product is fixed.
 - **Variable product** — Unit price varies by product weight or content (e.g., fruit and vegetables, meat, cheese, rope, chain, fabric, carpets on a roll, etc).
 - Is the product a base unit or a higher-level unit?
 - **Base unit** — A base unit product cannot be broken into other products that are sold separately (e.g., a jar of fruit jam).
 - **Higher-level unit** — A higher-level product can be broken down into other products that are sold separately (e.g., four jars of one type of fruit jam, or four jars of different types of fruit jam).

1. Get started
2. Describe your product
3. Get a GTIN

Tell us about your product

Answer these questions to get started.

Is the product sold to consumers?

Yes

The product is sold to consumers at point-of-sale

No

The product is not sold to consumers at point-of-sale

Is the product fixed or variable?

Fixed product (recommended)

Product is always the same. You can use Activate to get a GTIN and a barcode.

Variable product

Product varies by weight or dimension. You can use Activate to get a GTIN but not to get a barcode.

Is the product a base unit or a higher-level unit?

Base unit

The product cannot be broken into other products that are sold separately (e.g. a jar of jam)

Higher-level unit

The product can be broken down into other products that are sold separately (e.g. a multi-pack, a case of shampoo)

Next

Figure 5-3: Step 1 of the product wizard

! **Important:** Upload base unit products first; this is required to later add higher-level units. After you answer these three questions, click **Next**. You will then see the summary of your choices on the next page where you can add the product attributes.

Describe your product

You are creating a fixed, base unit to be sold to consumers. [Change product type](#)

Figure 5-4: Product Type

In case that you want to change the product type, for example from fixed to variable, you can click the **Change product type** link to return to the previous one.

✓ **Note:** If your product is a base unit, see section 5.2 [Describe your product — base unit](#). If your product is a higher-level unit, see section 5.3 [Describe your product — higher-level unit](#).

5.2 Add a base unit product

This section describes [Step 2](#) and [Step 3](#) options applicable to a base unit product.

5.2.1 Step 2 – Describe your product

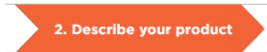

Figure 5-5: Step 2 of the product wizard

5.2.1.1 Brand name and sub-brand



 A screenshot of a web form titled "Describe your product". Below the title is the text "You are creating a fixed, base unit to be sold to". There are two main sections: "Brand name *" and "Sub-brand Optional". Each section has a dropdown menu with "Dabur" and "Michelin" for brands, and "Hair oil" and "Orangeburst" for sub-brands. There are "More" dropdown arrows next to each menu. Below each dropdown is a link: "Create a new brand" and "Create a new sub brand".

Figure 5-6: Base unit product options

To add a brand name and sub-brand

1. Select an existing brand name (mandatory). Alternatively, click **Create a new brand** to add a new brand name.
 2. Select an existing sub-brand (optional). Alternatively, click **Create a new sub-brand** to add a new sub-brand.
-  **Note:** When you describe your product, the identification values that you provided in [Manage suggestions](#) are presented to you. This helps you to quickly select appropriate information. Click **More** to see the whole list and to select from these suggestions.
3. As you work through this page, at the bottom, guidance messages or notifications shall appear informing you about the fields that you are yet to complete.

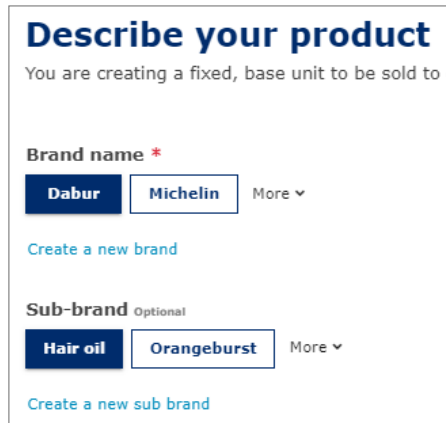

 A notification box with a light orange background. It contains the text "Complete the following fields to move to the next step:" followed by a bulleted list: "Brand name", "Functional name", "Net content", and "Country of sale". At the bottom of the box are two buttons: "Previous" and "Next".

Figure 5-7: Notifications

5.2.1.2 Functional name, variant and net content

4. Provide the text or measurements for these descriptions in a free text format.

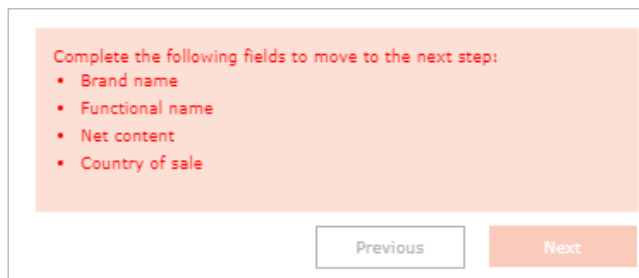
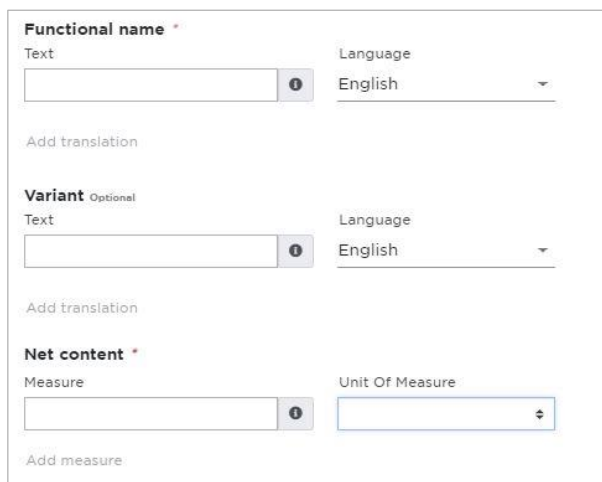
- **Functional name** (required) – Describe the item, for example, (strawberry jam, apple pie, basil salad dressing, tomato soup, light beer, floral women blouse, wooden picture frame).
- **Variant** (optional) – Provide the Consumer Product Variant (CPV). Identify the distinguishing characteristics that differentiate products that have the same brand and size, for example, (flavour, fragrance, taste, colour). The CPV identifies product variations that are considered insignificant to supply chain business processes, but that may be important to consumers.
- **Net content – Measure and Unit of Measure** (required) – The information you provide for Net content changes according to the definition of your product. This field is available for higher-level products.
 - In **Measure**, type a number for the correct unit of measure.
 - In the **Unit Of Measure** drop-down list, select the correct unit of measure type. For example, 400 Grams, 1 Litre, etc.
 - If there are multiple items in a single, base unit product, enter the net total. For example: for six chocolate bars at two ounces each, enter “12” “ounces.” For one twelve-ounce chocolate bar, also enter “12” “ounces.”
 - If the product is sold as a variable unit of measure, indicate only the **Unit Of Measure**. The **Measure** field will not be available for variable products.



The screenshot shows a form titled 'Product options' with three main sections:

- Functional name ***: A text input field and a language dropdown menu set to 'English'. Below it is an 'Add translation' link.
- Variant Optional**: A text input field and a language dropdown menu set to 'English'. Below it is an 'Add translation' link.
- Net content ***: A 'Measure' text input field and a 'Unit Of Measure' dropdown menu.

Figure 5-8: Product options

Net Content – Unit Of Measure list

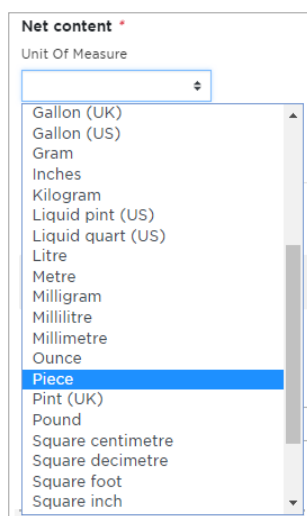

The screenshot shows a dropdown menu for 'Unit Of Measure' with the following items listed:

- Gallon (UK)
- Gallon (US)
- Gram
- Inches
- Kilogram
- Liquid pint (US)
- Liquid quart (US)
- Litre
- Metre
- Milligram
- Millilitre
- Millimetre
- Ounce
- Piece** (highlighted)
- Pint (UK)
- Pound
- Square centimetre
- Square decimetre
- Square foot
- Square inch

Figure 5-9: Base unit product option

5.2.1.3 Countries of Sale and Global Product Category code

5. From the **Countries of Sale** drop-down list, select the countries where the product shall be sold (required). If you have already chosen countries of sale on the **Manage Suggestion** page, they will show up first in this drop-down. Select as many countries as needed by choosing a country or a region (e.g., Middle East, Asia, Africa or "whole world").

 **Note:** For Countries of Sale, the country identification values that you provided in [Manage suggestions](#) are presented to you.

6. Select the **Global Product Category code** (required) – the unique primary GPC classification category number for the trade item (brick).
 - a. Start to type a category, such as "Jam" or "Marmalade" to see items listed alphabetically.
 - b. Select the GPC code that is the best match for your product.

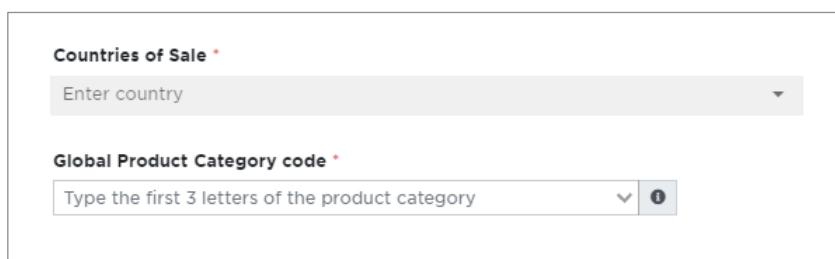

The screenshot shows two form fields. The first is a dropdown menu labeled 'Countries of Sale *' with the placeholder text 'Enter country'. The second is a dropdown menu labeled 'Global Product Category code *' with the placeholder text 'Type the first 3 letters of the product category' and an information icon.

Figure 5-10: Countries of Sale and default GPC options

 **Note:** For information about GPC codes, see <https://www.gs1.org/standards/gpc>.

- To look up GPC Brick code for all products: <https://www.gs1.org/services/gpc-browser>.

 **Note:** If your Member Organisation, opts to use a simplified GPC format, the **Product category** and **Product sub-category** fields shall appear instead of the **Global Product Category code** field.

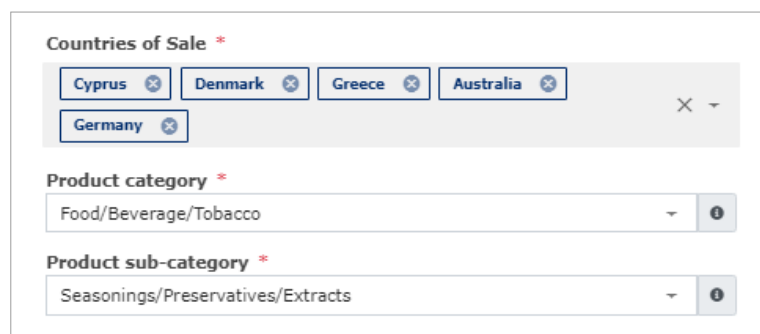

The screenshot shows a form with three main sections. The first is 'Countries of Sale *' which is a multi-select field containing 'Cyprus', 'Denmark', 'Greece', 'Australia', and 'Germany'. The second is 'Product category *' with a dropdown menu showing 'Food/Beverage/Tobacco'. The third is 'Product sub-category *' with a dropdown menu showing 'Seasonings/Preservatives/Extracts'. Each dropdown has an information icon.

Figure 5-11: Simplified GPC options – Product category and Product sub-category fields

5.2.1.4 Product image

7. Optionally, provide product images less than 2 MB. You can provide high-resolution product images in the following two ways: [uploading a file from your local machine](#) or [typing a Uniform Resource Locator \(URL\)](#) that conforms to W3C standards.

- ✔ **Note:** An image uploaded from your local machine gets precedence over a URL image. If the product image is not uploaded via the local machine, the first URL product image gets precedence over other URL images.

Product image recommendations

GS1 Product Image Specifications recommend that you adhere to the following guidelines to provide a high-resolution image:

Image appearance

The product image shall represent the primary selling surface of the product. Retailers should be able to use the image to authenticate the identity of the item. If possible, the product background should be white (RGB: 255/255/255).

Image resolution

300 Pixels Per Inch (PPI)

Image size range

2401 x 2401 to 4800 x 4800 pixels

File naming convention

For naming the image file, we recommend using the Global Trade Item Number (14-digit format GTIN) of the product. For example, you can name the image file as **09520000012342.jpg** and use the following URL format: **http://www.yourcompanyname.com/09520000012342.jpg**.

- ✔ **Note:** Ensure your image is not behind a firewall. Ensure the product image URL points to the original location where the image resides, regardless of whether the URL belongs to your company website or your solution provider.

To upload an image file from your local machine

- a. Click **Upload a file** and choose a product image. Alternatively, drag-and-drop the product image from your local machine.

- ✔ **Note:** Supported image file formats are GIF, JPG and PNG.

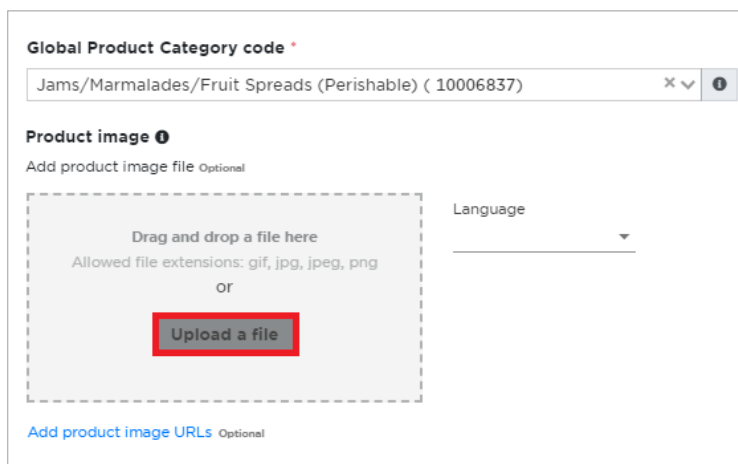

Figure 5-12: Upload product image file

- b. From the **Language** drop-down, select the main language of packaging.
- c. Optional: If you are not happy with the product image you uploaded, click **Select new image** to replace the product image.

- d. After you provide all the information, click **Next** to finalise the product.

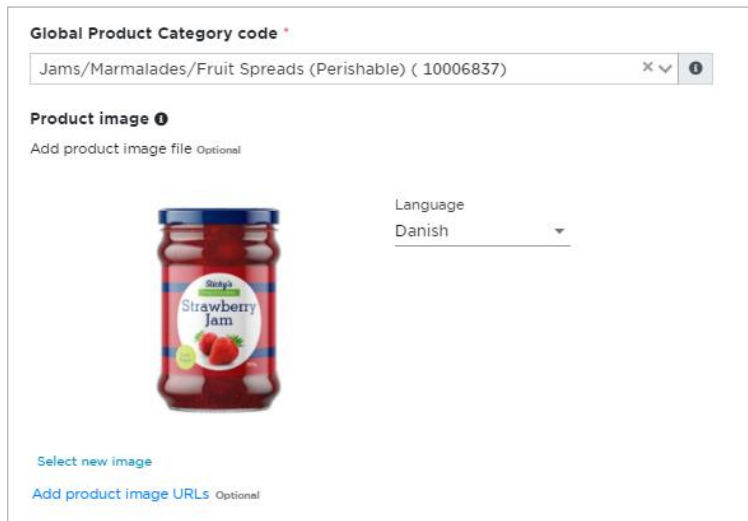

Figure 5-13: Product image – uploaded

To enter a URL or web address

- e. Click **Add product image URLs**. The **Image url** and **Language** options appear.

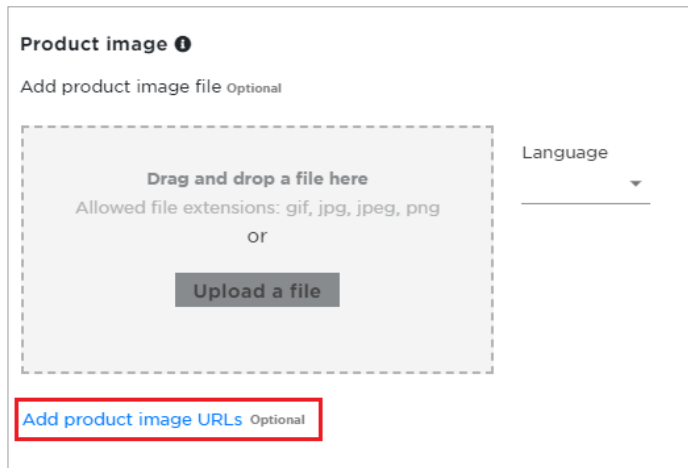

Figure 5-14: Add product image URLs option

- f. In **Image url**, type or paste an absolute URL of the product image. Once your product is finalised, the image you successfully uploaded can be replaced or deleted.
- ✔ **Note:** Supported image file extensions are GIF, JPG, PNG and SVG.
- g. From the **Language** drop-down, select the main language of packaging.



Figure 5-15: Image url and Language options

- h. After you provide all the information, click Next to finalise the product.

5.2.2 Step 3 – Get a GTIN

After you click **Next**, a product summary appears. Review your product description and information.



Figure 5-16: Edit, save a draft or finalise the product

You have three options:

- **Edit My Product** – If any information provided in step 1 and step 2 is incorrect, click **Edit My Product** to revise the information.
- **Save as draft** – If the information provided in step 1 and step 2 is correct, but you are not ready to finalise the product, click **Save as draft** (for example, you need a better image, you need to verify an attribute, etc.). This keeps all the information, including the image.

All products that you save as a draft are stored for you to review, edit, delete, and/or finalise at a future date. Draft products are not activated, and no information is shared among users of the GS1 Registry Platform. If you click **Save as draft**, see [Find draft products to edit and finalise](#).

- **Finalise** – When all information is validated and steps are complete, click **Finalise**. This commits the product and GTIN to the GS1 Key Registry, as indicated below.

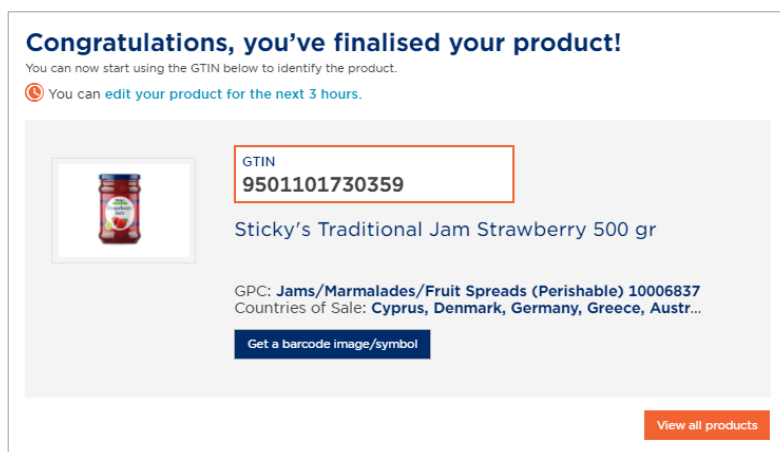

Figure 5-17: GTIN assigned to a finalised product

Congratulations! You've finalised your product! To create a barcode, click **Get a barcode image/symbol**. Continue with section 9, [Create barcode images](#).

5.3 Add a higher-level unit product

This section describes Step 2 and Step 3 options applicable to a higher-level product.

5.3.1 Step 2 — Describe your product

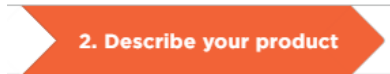

Figure 5-18: Step 2 of the product wizard

! **Important:** You must create or upload base unit products before you can create higher-level units.

About creating higher-level products

A higher-level unit product is a single product (with a unique GTIN) that is comprised of multiple base unit products. To create a higher-level unit product, you select the base unit product(s) to combine into a higher-level unit product. Therefore, base unit products must be created first.

- You can add fixed OR variable base unit products into a higher-level unit product.
- You cannot add fixed AND variable base unit products into a higher-level unit product.
- You can add one or more higher-level unit products to a higher-level unit product(s).

5.3.1.1 Select base unit products to create a higher-level unit product

1. To create a higher-level unit product, you must select the base unit products to include.

In this step, a list of all available base products is presented. This list is comprised of either all fixed, or all variable products, according to your choice in the previous step.

- To help find products you want to include, enter either a GTIN or at least three letters of a word in the title of the product, and press Enter to search.
- If you search by a GTIN, you can search on the last several digits (the initial digits will all have the same prefix).
- Select each product to include using a blue check . After you select the products as needed, click **Next**.

Figure 5-19: Base unit products to include in the new higher-level unit product

5.3.1.2 Enter the quantity of the base unit products and name the products

1. For each product that you add, specify the quantity that is included in the higher-level unit.
For example:

- Quantity 6 of Strawberry Jam Low Sugar 500 gr
- Quantity 6 of Strawberry Jam Real Sugar 500 gr

✔ **Note:** In this example, the base unit of each type of strawberry jam includes one jar. If your base unit is two jars (in a single package) for each type of jam, and you want the TOTAL number of jars in the higher-level unit to be 12 jars, enter a Quantity of 3 for each type of jam (2 jars times three base units equals 6 jars for each jam).

Figure 5-20: Quantity of the base unit products in the higher-level unit product

2. Enter the Quantity of each base product and click **Edit this description** to add product attributes: Brand, Sub-brand, Functional name, Variant, Countries of Sale, Global Product Category code and Product image. **Brand Name** and **Sub brand** fields display the selections made for the base products.

Figure 5-21: Other characteristics

For more details on completing these fields, see Step 2 of [Add a base unit product](#).

3. When this page is complete, click **Next**.
 - ✔ If you are a Payment On Demand Brand Owner, see [Raise a request to add a product \(for Payment On Demand brand owners\)](#).

5.3.2 Step 3 — Get a GTIN

After you click **Next**, a product summary appears. Review your information and product.

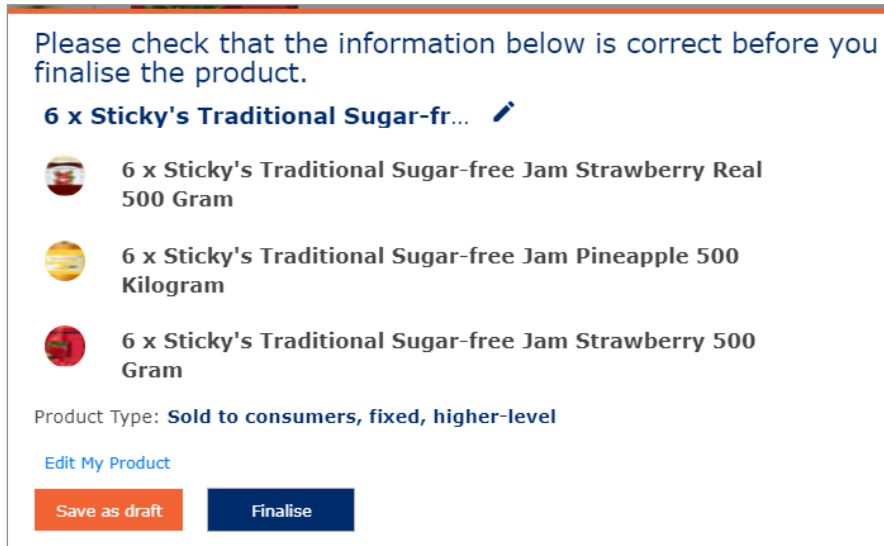

Figure 5-22: Edit, save a draft, or finalise the product

4. You have three options:
 - **Edit My Product** — If any information is incorrect, click **Edit Attributes** to revise the information.
 - **Save as draft** — If the information is correct but you are not ready to finalize the product, click **Save as draft** (for example, you need a better image, you need to verify an attribute, or you need another person to review and approve first). This keeps all of the information, including the image.

All products that you save as a draft are stored for you to review, edit, delete, and/or finalise at a future date. Draft products are not activated, and no information is shared among users of the GS1 Registry Platform. If you click **Save as draft**, see [Find draft products to edit and finalise](#).

- **Finalise** — When all information is validated and steps are complete, click **Finalise**. This commits the product and GTIN to the GS1 Key Registry, as indicated in [Figure 5-23](#).

Sticky's Traditional Jam Sugar-free in 3 flavors Active

🕒 You can edit your product for the next 2 hours 42 minutes.

GTIN
5309876786106

GPC: **Jams/Marmalades/Fruit Spreads (Perishable) (10006837)**
Product Type: **Sold to consumers, fixed, higher-level**

[Get a barcode image/symbol](#)

Products contained within higher-level unit

Description ↑	Quantity	GTIN
Sticky's Traditional Sugar-free Jam Pineapple 500 Gram	6	05309876786083
Sticky's Traditional Sugar-free Jam Strawberry 500 Gram	6	05309876786076
Sticky's Traditional Sugar-free Jam Strawberry Real 500 Gram	6	05309876786090

Figure 5-23: Finalised higher-level unit product

- Congratulations! you've finalised your product! To create a barcode, click **Get a barcode**. Continue with section 9, [Create barcode images](#).

5.4 Request a GTIN (for Payment On Demand users only)

Some users pay for GTINs individually. They are therefore not able to get GTINs directly via Activate. Instead, they need to follow the steps below:

1. Make a request for a GTIN to their GS1 Member Organisation ([Step 3](#)).
2. Pay their GS1 Member Organisation for the GTIN ([Step 3](#)).
3. Upon receipt of payment, your GS1 Member Organisation will then issue the GTIN ([Step 4](#)).

5.4.1 Step 3 – Request received

At Step 3 of the product wizard, all Payment On Demand users can see the following **Request received** page. This page contains a link for online payment.

1. Get started

2. Describe your product

3. Request received

4. Get a GTIN

Thank you for your request!

To get your barcode number/GTIN, please pay following the process described on <https://payments.com>.

We have sent you an email message with this information.

If you have any issues, [please contact us](#) .

[View all products](#)

Figure 5-24 : Request received

You shall also receive an email that specifies the link for online payment. On successful payment, a GTIN corresponding with your product is created. At the same time, an email is sent on your registered email ID specifying the product name and the corresponding GTIN. This information is also reflected on the GS1 Activate portal.

5.4.2 Step 4 — Get a GTIN

To view the new product details, from the home page click **Products**, then click product description of the product that you raised a request at step 3.

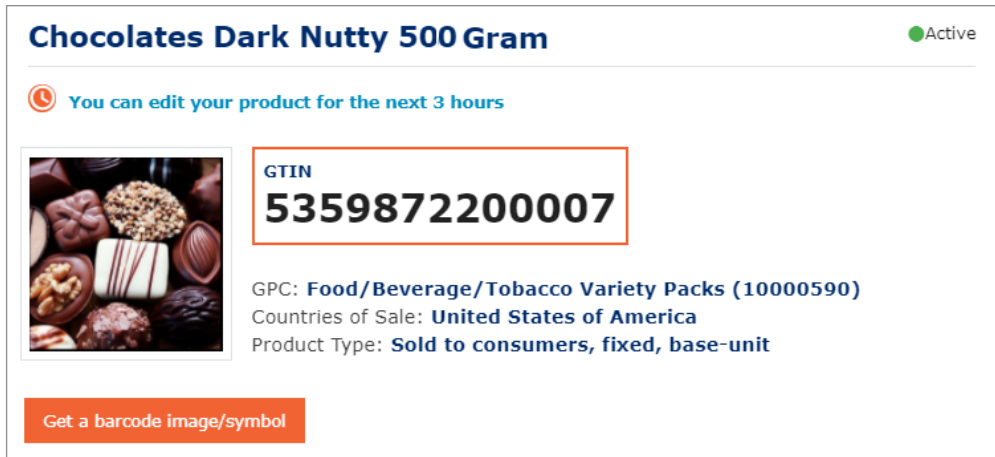



Figure 5-25: Product details after payment

- 
 When your MO adds or updates a company, licence, or user via the GCP MO tool, these details are immediately uploaded in Activate, while GRP is updated after a delay of 2 to 3 minutes only. Once the details are uploaded successfully, you can start creating products.

6 Edit, delete or finalise a base unit product

6.1 Find draft products to edit, delete and finalise

Information on draft products is unavailable to the GS1 Registry Platform users because draft products are not activated. All products that you save as drafts are stored for you to review, edit, delete or finalise at a future date.

To edit, delete or finalise a draft product:

1. From the home page, click **Products**.
2. Use the search feature to view products that are in draft status. In the product list, you can see **Active** and **Draft** products.

To know more about the search feature, see section 4, [View, search and sort product lists](#).

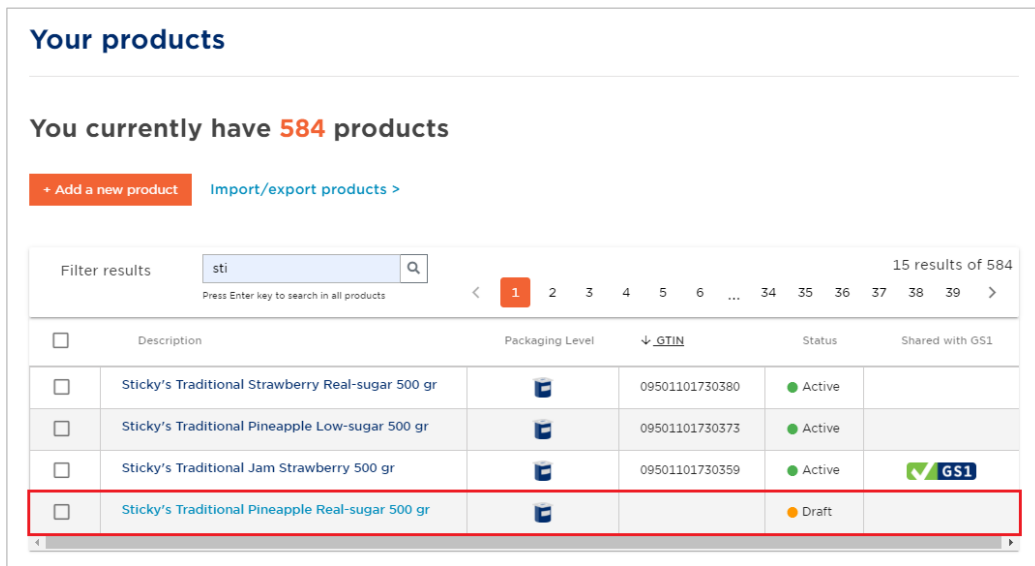

Your products

You currently have **584** products

+ Add a new product [Import/export products >](#)

Filter results: sti 15 results of 584

<input type="checkbox"/>	Description	Packaging Level	↓ GTIN	Status	Shared with GS1
<input type="checkbox"/>	Sticky's Traditional Strawberry Real-sugar 500 gr		09501101730380	● Active	
<input type="checkbox"/>	Sticky's Traditional Pineapple Low-sugar 500 gr		09501101730373	● Active	
<input type="checkbox"/>	Sticky's Traditional Jam Strawberry 500 gr		09501101730359	● Active	
<input type="checkbox"/>	Sticky's Traditional Pineapple Real-sugar 500 gr			● Draft	

Figure 6-1: Your products page displaying product status

3. Click the product GTIN to open a draft product.
4. Click **Edit this product**.
5. Review and edit the product information, as needed.
6. Select an option:
 - **Delete** — It's deleted forever.
 - **Save** — Continue to save as a draft.
 - **Finalise** — Save the product selections and assign a GTIN.

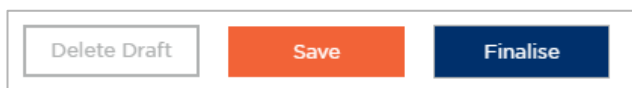

Figure 6-2: Options for draft products

! For Payment On Demand users, when you finalise a draft product, a GTIN approval request is raised and notification is triggered to your MO. Once approved by your MO administrator you shall find a corresponding GTIN associated with your specific product on the **Your products** page.

6.2 Editing product attributes during the 3-hour editing period

As soon as you finalise a product, you have a three-hour window to edit product attributes.

1. On the **Products** page, search and click the product you created, and then click **edit product attributes for the next 3 hours**.

The previous product information page re-opens.



Figure 6-3: Option to edit a product during the three-hour editing period

2. Edit the product information, as needed.
3. Click **Update**.

After you click **Update**, the three-hour countdown clock does not reset; it continues from the initial time it started. You CAN re-edit as many times as you like – within the three-hour window.

6.3 Editing product attributes after the 3-hour editing period elapses

After the three-hour period has elapsed, the GTIN assigned to your product shall be dedicated to this product and cannot be reused.

Therefore, all the following product attributes constituting the product description cannot be edited:

- Brand name
- Sub brand name
- Functional name
- Variant
- Net content (unavailable for higher-level unit products)

- !** **Important:** If you need to edit an attribute due to a typing error, please contact your GS1 member organisation. Once your MO facilitates, a 24-hour time period on the **Products** details page, the following message appears. To continue to edit, click **You can edit your product for the next <remaining time>**.



Figure 6-4: Option to edit a product during the 24-hour period

The following attributes can be added or edited even after the 3-hour period has elapsed:

- Global Product Category
- Product image
- Countries of Sale

7 Import a batch of products with a data file

To upload and quickly render many products active, use this procedure to upload product information in an Excel spreadsheet file (or, 'template').

- Download the template from the GS1 Activate User Interface.
- Export data from your system (in a pre-set format) and place it in the template.
- Upload the file to GS1 Activate and finish the activation step for each product.

Download the proper template

There are two templates that you can use to upload data. The templates are different depending on whether:

- You want to assign specific GTINs to each product or,
- You want GS1 Activate to assign an available GTIN to each product

 Please do not change the names of sheets.

Template overview

- The templates are the same, with the exception that one sheet does not include a column for GTINs.
- The templates are created based on the MO language.
- All green coloured columns in the template are mandatory. The language column will be used for both functional name and variant. Drop-downs are available for appropriate columns.

To download the import template

1. On the **Products** tab, click **Import/export products**.
2. Click **Import products** and then click **Next**.



Figure 7-1: Import/export products page

3. Select **Yes** or **No** to "Do the products that you want to import have GTINs?" and click **Next**.

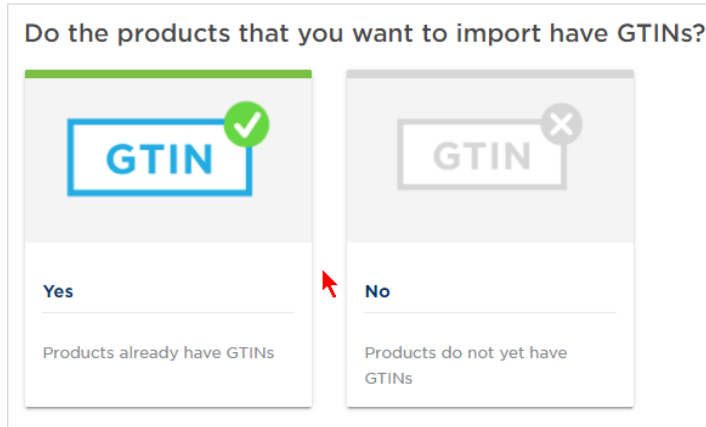

Figure 7-2: Import product with GTINs

4. Click **Import template** to start the download.

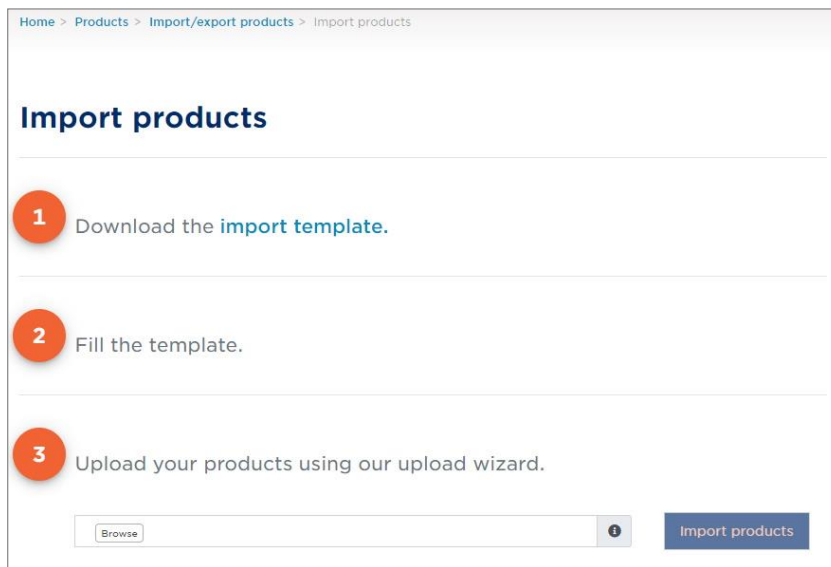

Figure 7-3: Steps to import products

- ! Payment On Demand products cannot be imported in Activate, as the products do not contain their corresponding GTINs. The following message is displayed, if you try importing products without GTINs.



Figure 7-4: Importing POD products

7.1 Fill in the template

This section provides instructions for both templates. The difference between the templates is one column of data – the GTIN column.

The template includes three sheets.

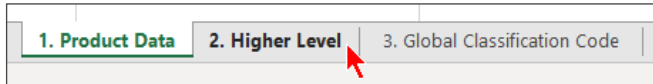

Figure 7-5: Import template

- **Product Data** – 20 mixed columns required and optional data columns
- **Higher Level** – Three required, and several optional data columns. These columns define the base and higher-level products.
- **Global Classification Codes** – Provides a link to the GS1 GPC dictionary

7.1.1 Product Datasheet – attributes

Use this sheet to provide product information. Required attributes are highlighted with shading and an asterisk. The remaining attributes are optional.

Attribute	Definition
GTIN	For products that already have a Global Trade Item Number (GTIN), enter the number in 14-digit format. Leave blank if your product does not yet have a GTIN number. E.g., 09501234600017
Brand Name *	Provide the product's primary brand name shown on the package. Format: up to 70 characters E.g., <i>Sticky's</i>
Sub Brand	Provide the product's secondary brand name (if used). Format: up to 70 characters E.g., <i>Traditional, Organic</i>
Language *	Provide the first language used for the product's functional name and variant. <i>Select from the drop-down list</i>
Functional Name *	Describe the main function of the product. Format: up to 35 characters E.g., <i>Strawberry Jam, Washing Powder, Mineral Water</i>
Variant	Provide the product variant where different varieties of the same product exist. E.g., <i>Low Sugar</i>
Language 2	Provide the second language used for the product's functional name and variant. <i>Select from drop-down list</i>
Functional Name 2	Provide the functional name in a second language.
Variant 2	Provide the variant in a second language.
Language 3	Provide the third language used for the product's functional name and variant. <i>Select from drop-down list.</i>
Functional Name 3	Provide the functional name in a third language.
Variant 3	Provide the variant in a third language.
Country of Sale *	The code representing the country where the trade item is intended to be sold. <i>Select from drop-down list.</i>
Country of Sale 2	Second country of sale. <i>Select from drop-down list.</i>
Country of Sale 3	Third country of sale. <i>Select from drop-down list.</i>

Attribute	Definition
Global Product Category Code *	The GS1 Global Product Classification code used to group products based on similar characteristics. Format: 8 digits <i>E.g., 10000217</i> <i>See the global classification code tab for more information.</i>
Net Content *	The quantity of product contained by the packaging. Format: up to 15 digits and up to 5 decimal positions <i>E.g., 400</i>
Net Content Unit of Measure *	The unit of measure used for the net content <i>Select from drop-down list.</i>
Point-Of-Sale/ Not Point-Of-Sale *	Indicate whether the item is sold to consumers. <i>Select from drop-down list.</i>
Fixed / Variable *	Indicate whether the item is sold in a fixed quantity or a variable quantity (such as weight, length or volume). <i>Select from drop-down list.</i>

7.1.2 Higher-level sheet-attributes

Use this sheet to provide information to create higher-level units. This sheet is optional – if there are no higher-level products, leave this sheet blank.

If you create a higher-level unit, the required attributes are highlighted with shading and an asterisk. The remaining attributes are optional.

- If you have higher-level units, at least one lower-level GTIN must be defined. If you select multiples of the same lower-level GTIN, that creates a higher-level unit
- You do not need to mix different lower-level GTINs to create a higher-level unit

Item Level	Attribute	Description
	POS / Not for Consumer *	Define whether or not the higher-level unit is sold to consumers. <i>Select from drop-down list.</i>
	Fixed/Variable *	Define whether or not the higher-level unit is sold in a fixed quantity or a variable quantity (such as weight, length or volume) <i>Select from drop-down list.</i>
	Trade Item Description *	Description (only required if the higher-level unit contains more than one lower-level product)
First GTIN included in the higher-level unit	Lower Level GTIN *	Provide the GTIN of the first base unit included in the higher-level unit
	Quantity of lower Level * GTIN	How many of these base units are included?
Second GTIN included in the higher-level unit	Lower Level GTIN	Provide the GTIN of the second base unit included in the higher-level unit
	Quantity of lower Level GTIN	How many of these base units are included?
Third GTIN included in the higher-level unit	Lower Level GTIN	Provide the GTIN of the third base unit included in the higher-level unit
	Quantity of lower Level GTIN	How many of these base units are included?

7.1.3 Instructions tab

This tab provides additional instructions and information.

- For information about GPC codes, see: <https://www.gs1.org/standards/gpc>
- To find GPC Brick code numbers for your products, see: <https://www.gs1.org/services/gpc-browser>

7.2 Upload products using the template upload wizard

When the template is complete (filled in with product information) use the wizard to upload the data.

1. In step 3 on the **Import products** page, select the file to upload, and click **Import products**.

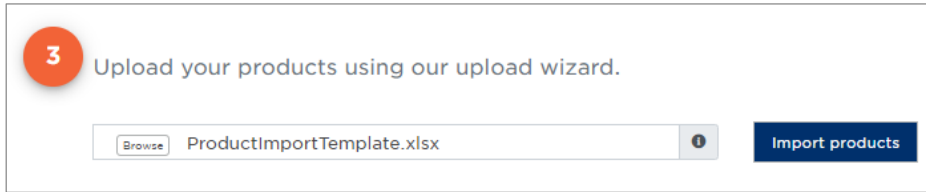

Figure 7-6: Template uploaded

GS1 Activate shall upload all rows (product records) that do not have any errors. After the upload, if there are no errors, a status message confirms that all products have been added successfully.

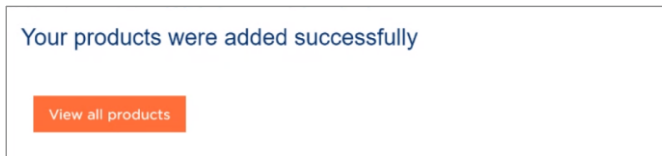

Figure 7-7: Products uploaded successfully

2. If there are any errors in the data you upload, GS1 Activate will alert you to the error(s). For example, in the following images (of two separate file uploads), two errors are identified:
 - Duplicate: Product already exists
 - Invalid: GTIN not available in the prefix range
3. Fix the incorrect information and try the upload again.

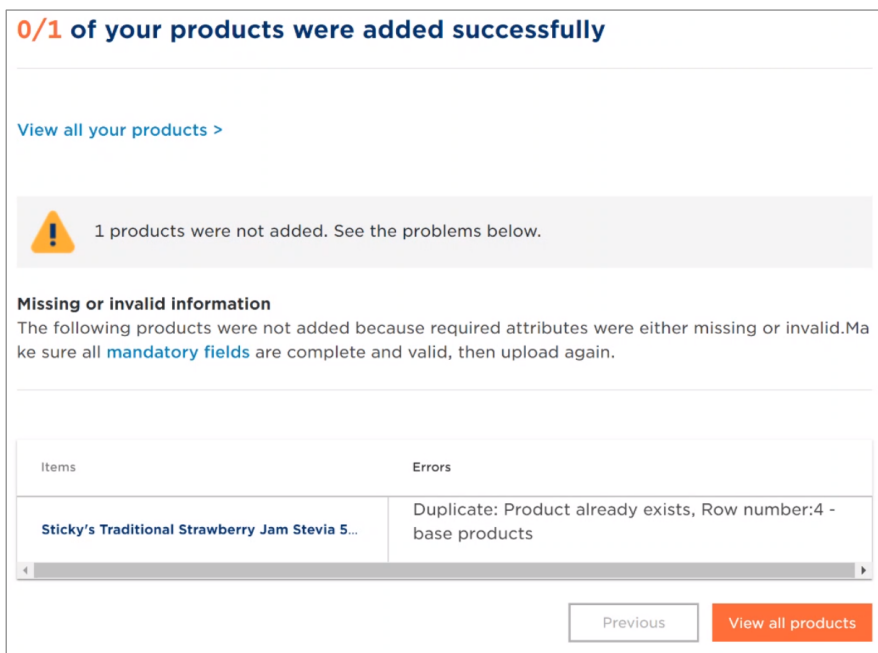



Figure 7-8: Upload errors

0/1 of your products were added successfully

[View all your products >](#)

 1 products were not added. See the problems below.

Missing or invalid information
The following products were not added because required attributes were either missing or invalid. Make sure all **mandatory fields** are complete and valid, then upload again.

Items	Errors
Sticky's Traditional Strawberry Jam Stevia 5...	Invalid: GTIN not available in the prefix range, Row number:4 - base products

[Previous](#) [View all products](#)

Figure 7-9: Upload errors

8 Create barcode images

There is only one method available to generate barcode images for products. Each image must be generated manually — one at a time — using GS1 Activate. There is no batch function to generate or download barcodes.

Special rules apply in creating barcodes via GS1 Activate for variable products (variable by weight, price and content). Therefore, GS1 recommends getting in touch with the GS1 Member Organisation for further information.

To generate a barcode image

1. On the product information page, use the search feature described in this guide, for example, "500 gr" to find your product.
2. Click on the product description, for example, "Sticky's Traditional Strawberry Jam Low Sugar 500 gr".

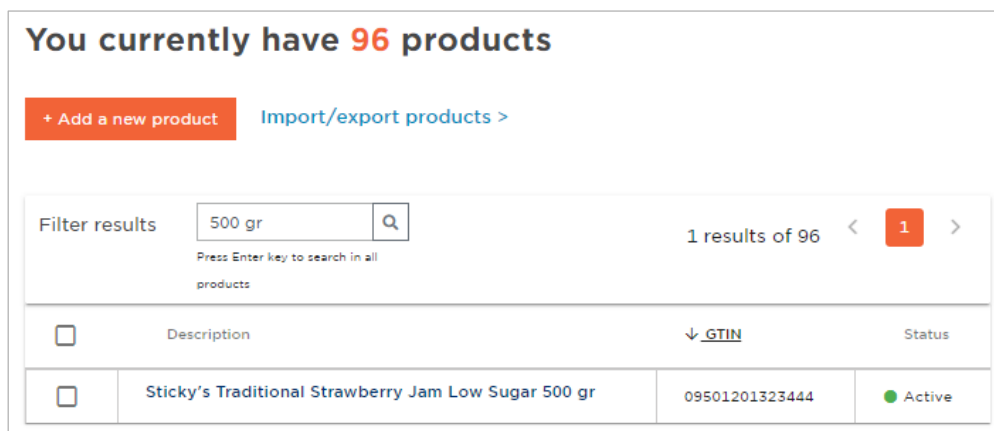

Figure 8-1: Search result for 500 gr

The product information page opens.

3. Click **Get a barcode image/symbol**. The **Get barcode** page opens.



Figure 8-2: Product information

4. Select the type of Barcode file format. You can generate both if you need both types.
 - **PDF format** — Recommended for previewing your barcodes
 - **EPS format** — Recommended for sending to packaging printers

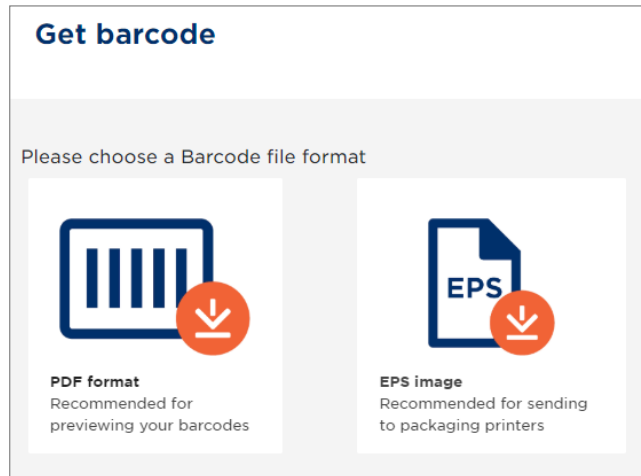

Figure 8-3: Get barcode page

The image file is downloaded into your browser.



Figure 8-4: Image downloaded

5. Open the file to check the barcode.



Figure 8-5: Product barcode

 **Note:**

- In accordance with the GS1 Global Standards, GS1 Activate supports the creation of barcodes for products with a fixed price and net content. An overview is listed in Appendix 3.
- If you need a barcode for a variable product (varies by net content), please contact your local GS1 Member Organisation.

9 Export products

To help with inventory management, you can download all or a part of your product catalogue in an Excel spreadsheet. The options you have are:

- Choose products for a specific licence.
- Choose All -or- base unit -or- higher-level products.

To export products

1. Click the **Products** tab and then click **Import/export products**.
2. On the **Import/export products** page, select **Export products** and click **Next**.



Figure 9-1: Import/export products page

3. On the **Export products** page, select either **All my products** or **Selected products**.
 - If you choose **All my products**, click **Export products**.

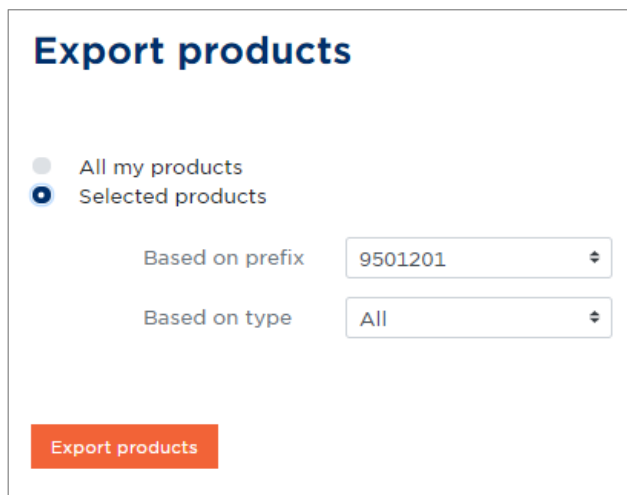

Figure 9-2: Selected products options

- If you choose **Selected products**:
 - Select which prefix you want to see products in **based on prefix**.

- Select which type (**All**, **base products**, or **higher level products**) you want to see products for in **based on type**.

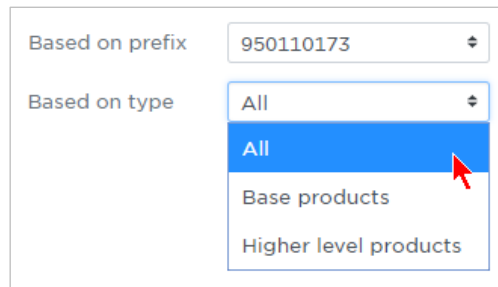

Figure 9-3: Based on type options

4. Click **Export products.**

The Excel file is downloaded to your local machine.

Product information included in the export file

- Type of the product
- Global Trade Item Number (GTIN) is the barcode number of the product, 14 digits long. Leading zeros are needed for GTIN 13, 12 and 8's. Format: 14 digits (n14). E.g., 05391234567892
- The name provided by the brand owner that is intended to be recognised by the consumer. Format: up to 70 characters (an. 70). E.g., Johns Jams.
- Second level of the brand. Can be a trademark. Format: up to 70 characters (an. 70). E.g. Yummy-Strawberry Classic.
- Language used for functional name and variant (if applicable) on the product. Select from drop down.
- Describes the use of the item/product by the consumer that is what the customer would call the product. Format: up to 35 characters (an. 35). E.g., "jam", "soup", "shampoo" etc.
- Second language used for functional name and variant (if applicable) on the product. Select from drop down.
- Functional name in second language
- Variant in second language
- Third language used for functional name and variant (if applicable) on the product. Select from dropdown.
- Functional name in third language
- Variant in third language
- The code representing the country where the product/service is intended to be sold. Select from drop down.
- Second country of sale
- Third country of sale
- The quantity of the product contained in the package, typically printed on the label for the selling market. Format: up to 15 digits (n. 15) up to 5 decimal positions. E.g., 400.
- The unit of measure: typically printed on the label for the selling market. Select from drop down.
- Definition of the unit if it intended to be a Point of Sale trade item or Not for Consumer purposes.
- Indicates the item is not a fixed quantity but is variable in e.g., weight, length or volume. Format: Fixed/Variable.

10 Share product data with GS1

In accordance with the user agreement of your GS1 member organisation, products created in GS1 Activate are automatically uploaded to the GS1 Registry Platform.

The registry platform is a database for all GTIN-related product data. It allows other GS1 member companies, such as retailers or marketplaces to verify GTINs for making sure that a product and its GTIN is valid.

Essential mandatory attributes to allow a GTIN verification are:

- GTIN
- Product Description (Brand name, functional name, net content)
- Global Product Category

For allowing a good product verification it would however be recommended to provide all attributes including:

- Product image
- Countries of Sale

Every night, all newly created and finalised or updated product records shall be uploaded to the GS1 Registry Platform.

A GS1 icon on the **Your products** page indicates the following product upload status:



Green icon indicates that a GTIN product record has been shared with all required product attributes.



Grey icon indicates that a GTIN product record has been shared with some attributes missing (e.g., the product image). If you complete the product record, later on, it will be updated in the GS1 Registry Platform overnight.

For checking the GTIN upload, view the list of all your products created in GS1 Activate:

You currently have **260** products

[Add a new product](#) [Import/export products >](#)

Filter results Press Enter key to search in all products 15 results of 260









<input type="checkbox"/>	Description	Packaging Level	GTIN	Status	Shared with GS1
<input type="checkbox"/>	Brand4 cake pops low sugar		09508877000075	Active	
<input type="checkbox"/>	Brand 6 Cake Pop		09508877000068	Active	
<input type="checkbox"/>	Yummy Finest Blueberry Pie Sugar free 300 gr		09508877000051	Active	
<input type="checkbox"/>	Birgit's Finest Blueberry Pie Low Carb 500 gr		09508877000044	Active	

Figure 10-1: Your products page

Or, look up a single product:

Brand4 cake pops low sugar

 You can edit this product.



GTIN
9508877000075

GPC: Cakes - Sweet (Perishable) (10000171)
Countries of Sale: **Andorra**
Product Type: **Sold to consumers, fixed, base-unit**

[Get a barcode image/symbol](#)



GS1 AISBL 2019 | [Terms of Use](#) | [Privacy Policy](#)

Figure 10-2: Product information

-  **Note:** Only base units of products with fixed measures that are sold to consumers will be shared with GS1.

11 Appendices

A.1 Appendix 1 – Examples of product classification: selecting the right properties

To make the right selection for the properties and the attributes; 'net content' and 'unit of measure' for your products, use the following table for guidance.

- Is this product sold to consumers?
 - Yes, if this product is sold as-is to the consumer
 - No, if this product is not intended to be sold to consumer but sold to e.g., wholesalers
- Are the contents fixed?
 - Fixed products are usually pre-packaged goods with a consistent content e.g., cans of soda, jars of jam, packs of rice, etc.
 - Variable products are very often natural products that have no pre-defined weight e.g., meat, poultry, fruits, vegetables, etc.
- How is your product measured?
 - For fixed products, use the unit of measure indicated on your label
 - For variable products, indicate the unit of measure this product is traded in
- What is the content?
 - How much is included in your product based on the unit of measure?

Example of Product	Is this product sold to Consumers?	Are the contents Fixed?	Sold individual or packaged?	How is it measured?	What is the content?
	YES / NO	Fixed / Variable	base / higher level	Unit of Measure	Net Content
One jar of jam	Yes	Fixed	base	Grams	500
Case of 6 wines	Yes	Fixed	higher level	N/A (see note 1)	6 {bottles of wine}
One Chicken breast	Yes	Variable	base	Pounds	N/A (see note 2)
A pack of chicken breasts	Yes	Variable	higher Level	N/A (see note 1)	8 {chicken breasts}
Case of 24 jars of jam	No	Fixed	higher level	N/A (see note 1)	24 {Jars of Jam}
Wheel of cheese (see note 3)	No	Variable	base	Kilograms	N/A (see note 2)
Case of 6 wheels of cheese	No	Variable	higher level	N/A (see note 1)	6 {wheels of cheese}



Notes:

- The higher-level products are only expressed in how many items of the base product are included in the higher-level item.

- The content is unknown as this is a variable product, therefore this option is not available.
- In this example, the wheel of cheese is intended to be sold to a supermarket, who in turn sells the product on demand in smaller portions to the customer.

A.2 Appendix 2 – Using the indicator digit method

Some Member Organisations enable the option to specify an indicator digit.

Products that are sold to consumers always have a 13-digit GTIN. Products that are not sold to consumers sometimes have a 14-digit GTIN. When a 14-digit GTIN is used, then an additional digit called an "indicator digit" is added to the start of the 13-digit GTIN to make it 14-digits, as in the following cases:

- When the product is a variable measure. In this case, an additional 9 is added to the 13-digit GTIN.
- When a product is sold in a higher-level unit that contains only one type of product. In this case, you can choose an indicator digit between 1 and 8 to indicate up to eight levels of packaging hierarchy. For example:
 - Product A is sold to consumers and receives GTIN 9501234600017
 - You sell product A to a retailer (not sold to a consumer) in cases that contain 48 products. Since this is the smallest case size, you choose indicator digit "1" for this case. GS1 Activate will then assign the GTIN 19501234600017 to this product.
 - You sell product A to another retailer in cases that contain 64 products. You choose indicator digit "2" for this case. GS1 Activate will then assign the GTIN 29501234600017 to this product.

The table below shows a summary view.

Is the product sold to consumers?	Is the product a base unit or a higher-level unit?	Is the product fixed or variable?	Combination of higher level	Number of digits in GTIN	Indicator Digit
Sold to consumers	base unit	Fixed	N/A	13	
		Variable		13	
	higher-level	Fixed	Homogeneous pack	13	
		Variable		13	
	higher-level	Fixed	Mixed Pack	13	
		Variable		13	
Not sold to consumers	base unit	Fixed	N/A	13	
		Variable		14	9
	higher level	Fixed	Homogeneous pack	14	1-8
		Variable		14	9
	higher level	Fixed	Mixed Pack	13	
		Variable		14	9

A.3 Appendix 3 – Supported Barcodes

GS1 Activate supports the creation of barcodes for fixed products as shown in the chart below.

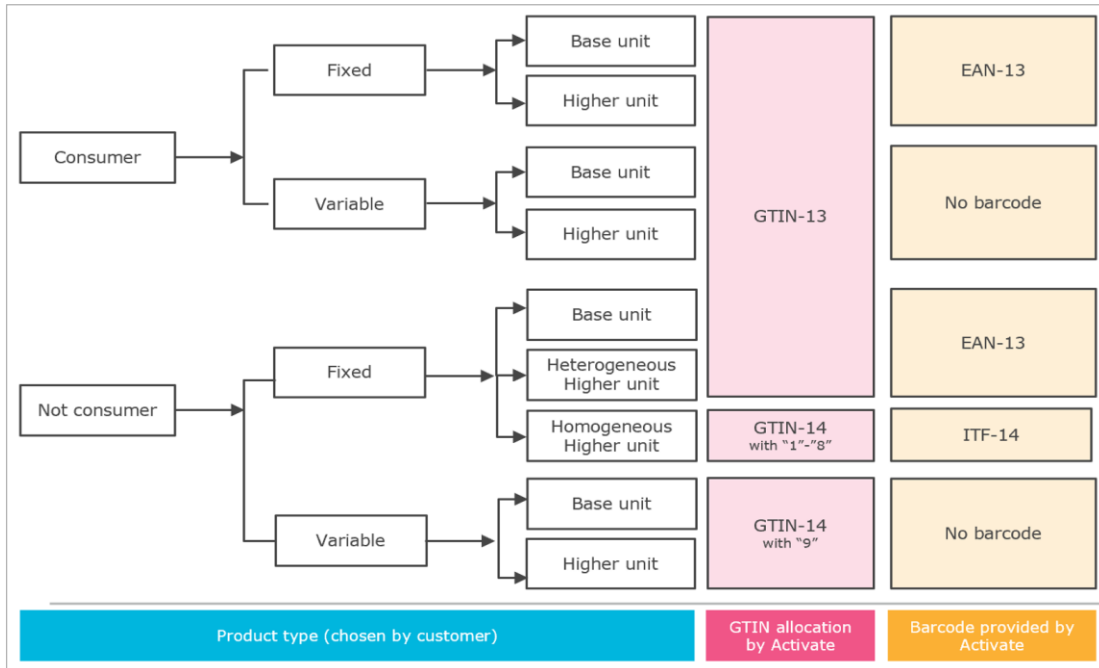

In addition, if you are given GTIN-8 licences by your GS1 Member Organisation, Activate will automatically create EAN-8 barcodes based on those licences (usually used for very small products).